



Picture is a representation of actual product.

Approvals



Order Information

Load Rating	Part #	Est. Weight	Price
40 ft Cable			
50,000 lb	21611	20 lb	Consult
65,000 lb	21612	20 lb	Consult
100,000 lb	21613	20 lb	Consult
60 ft Cable			
50,000 lb	107583	20 lb	Consult

Dimensions

Rated Capacity	A	B	D	E	F	G	H	J	K	L	M	N	P	Q	R
50,000 to 65,000	10.25	5.12	1.00	0.75	0.78	2.40	4.25	8.50	1.00	2.06	1/2-14 NPT	1.50	3.00	1.03	2.20
100,000	10.25	5.12	1.00	—	—	2.40	4.25	8.50	1.00	2.06	1/2-14 NPT	1.50	3.00	1.03	2.20

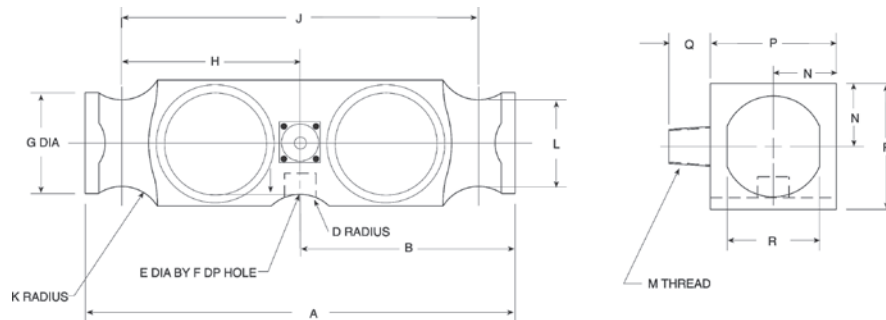

Interchangeable Products

- VPG® REVERE
5223page 257
- VPG® SENSORTRONICS®
65040A-XX-1127W..... page 298
- ARTECH®
80210
- THURMAN®
TSC 800
- UNIBRIDGE®
DL9000

Weigh Module Available

- RICE LAKE WEIGHING SYSTEMS
Translink.....page 75

Specifications

- Full Scale Output:**
3.0 mV/V
- Output Resistance:**
699 to 707 ohm
- Input Resistance:**
686 to 714 ohm
- Material/Finish:**
High-alloy steel
- Temperature:**
Compensated range
14 °F to 104 °F (-10 °C to 40 °C)
Operating range
0 °F to 150 °F (-18 °C to 65 °C)
- Seal Type:**
Welded-seal, IP67
- Safe Overload:**
150% full scale
- Safe Sideload:**
100% full scale
- Rated Excitation:**
5-10 VDC (15 V maximum)
- Non-repeatability:**
0.01% full scale
- Combined Error:**
0.03% full scale
- Insulation Resistance:**
5,000 megohm
- Deflection at Capacity:**
50,000 lb: 0.018 in
65,000 lb: 0.022 in
100,000 lb: 0.034 in
- Cable Length:**
40 ft
60 ft
- Cable Diameter:**
0.305 in polyurethane jacket
- Cable Color Code:**
Red +Excitation
Black -Excitation
Green +Signal
White -Signal
- Warranty:**
Two-year limited
- Approvals:**
cFMus
NTEP 97-126